

PAPER STRIP PUNCHES “MP” series

Precision Strip Punches to cut rectangular, square or circular precision samples with high accuracy, +/- 0,1mm, in order to evaluate *Tensile, basis weight, SCT, CMT, RCT, CCT...* for Paper (Liner / Medium) ...

- q Easy to operate
- q Rapidity and precision
- q Robust Construction

Rectangular Versions:

- q 15 x 300 mm
- q 12,7 x 152,4 mm
- q 25 x 300 mm
- q 210 x 297 mm. (DIN A4)
- q Precision: +/- 0,05 mm

MP-15 model - Code.T-3164

MP-10 model - Code.T-6908

MP-25 model

Circular Versions:

- q 100 cm²
- q 50 cm²
- q Precisión: +/- 0,1 mm

MP-100 - Code.T-6909

MP-50

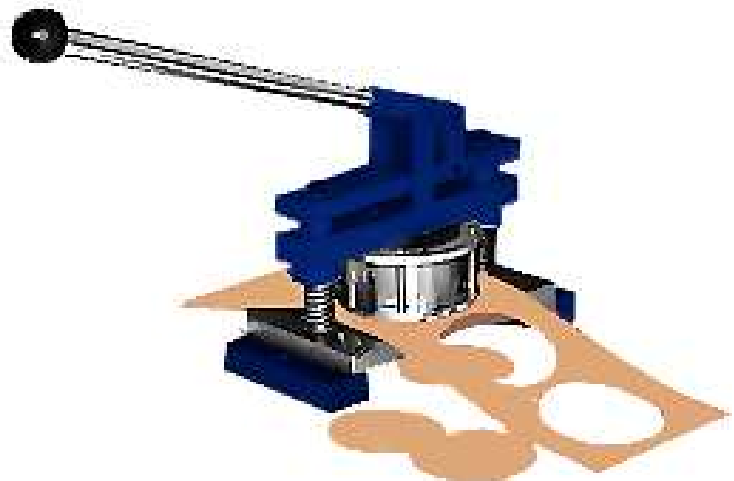
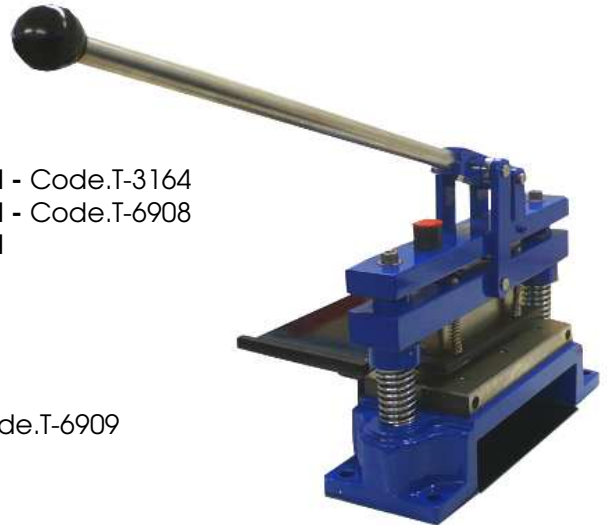

Robust Strip Punches for preparation of test strips towards use in tensile strength, basis weight, Cobb, SCT, CMT, RCT, CCT, CLT and other similar tests.

Punch & Die manufactured from tempered tool alloy steel to ensure long life.

NOTE: Other sizes, upon request